

Service insulation piercing connector



K322

K441

with yellow shear head indicator

Application

This connector is designed to connect the insulated service conductors to the low voltage A.B.C. (Aerial Bundled Conductors).

Description

Connector general features:

- Insulation piercing is carried out on the main and tap conductors simultaneously in a single tightening operation.
- The dielectric strength in water is greater than 6kV.
- The tightening screw is potential free.
- Tightening efficiency is ensured by a shear head screw.
- Connectors K441, K442 and K443 are fitted with a yellow shear head indicator that disappears when head is sheared-off, being a clear visual confirmation of good tightening from ground level. It increases head height by 10 mm.

This connector meets the criteria of the **NF C 33-020** and **EN 50-483** standards.

Connector end cap:

- The connector end cap is flexible so that to feel good tap conductor insertion simply by hand.
- It is carrying membranes instead of grease, granting watertightness around tap conductor end on long term basis.
- It is glued on connector body so that to avoid eventual loss during handling, installation and environment (wind, bad weather...).
- It can be equipped with a hard end cap, gripping and covering so, in case rigid cover is required. (Part Number K246 : please enquire for further information).

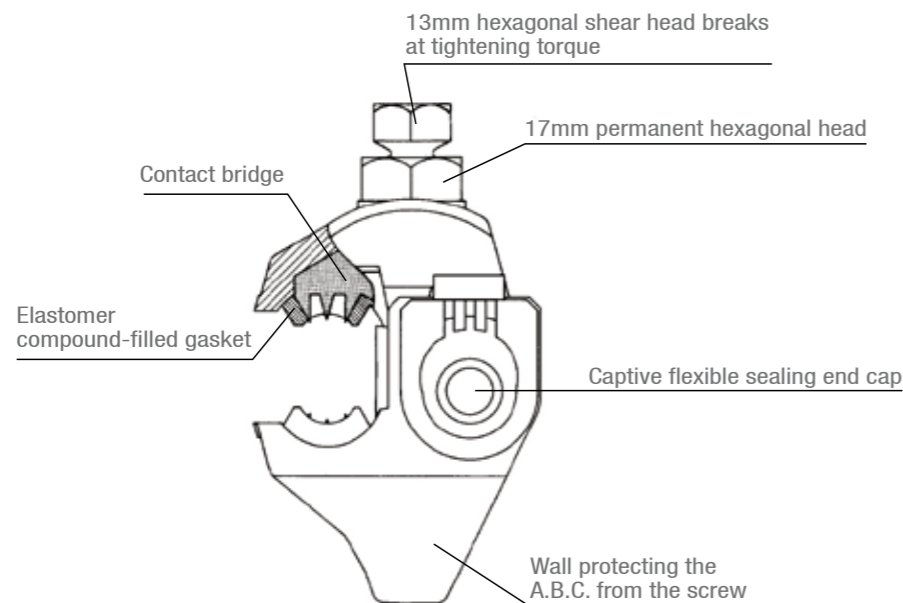

Installation video available on www.michaud-export.com

Code	Designation	Contact bridge	Capacities Main insulated Al-Cu (mm ²)	Capacities Tap insulated Al-Cu (mm ²)	Weight (kg)	Sales unit
ZINC-PLATED STEEL FASTENERS (ZF)						
K322	CONNECTOR CBS/CT 25 ZF - ERDF	Aluminium alloy	16-25	6-25 6M-35M	0.120	12
K323	CONNECTOR CBS/CT 70 ZF - ERDF	Aluminium alloy	16-70	6-25 6M-35M	0.120	12
K324	CONNECTOR CBS/CT 150 ZF - ERDF	Aluminium alloy	16-150	6-25 6M-35M	0.130	12
ZINC-PLATED STEEL FASTENERS (ZF)						
K331	CONNECTOR CBS/CT 70 ZF	Tinned brass	16-70	4-25	0.130	30
K332	CONNECTOR CBS/CT 95 ZF	Tinned brass	16-95	2.5-35	0.130	30
K330	CONNECTOR CBS/CT 150 ZF	Tinned brass	35-150	6-35	0.140	30
STAINLESS STEEL FASTENERS (SF) + YELLOW SHEAR HEAD INDICATOR						
K441	CONNECTOR CBS/CT 95 SF	Tinned brass	25-95	6-35	0.135	20
K442	CONNECTOR CBS/CT 150/1.5-25 SF	Tinned brass	35-150	1.5-25	0.140	20
K443	CONNECTOR CBS/CT 150/6-35 SF	Tinned brass	35-150	6-35	0.140	20

M means that the core of the conductor is solid.

Option: Service connector with movable seal cap

This connector is used for connecting the insulated service conductors to the low voltage A.B.C (Aerial Bundled Conductors). The movable sealing end cap enables a tap connection on the right or on the left. The main conductor connection and the tap ones use the insulation piercing technology.

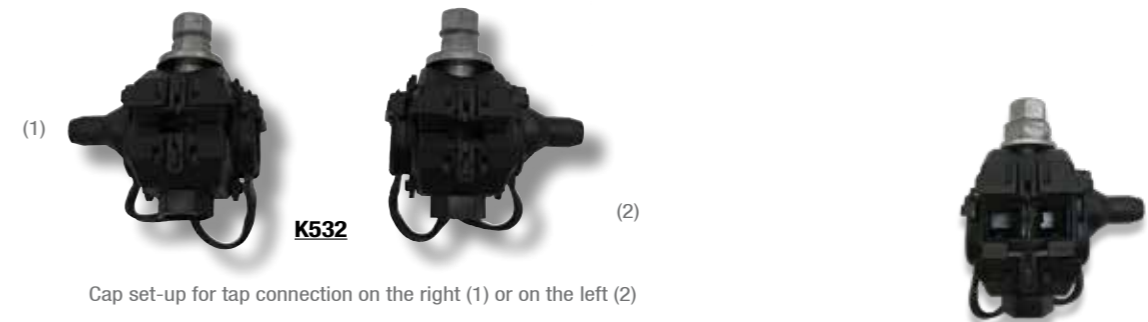

Cap set-up for tap connection on the right (1) or on the left (2)

L232

Code	Designation	Contact bridge	Capacities Main insulated Al-Cu (mm ²)	Capacities Tap insulated Al-Cu (mm ²)	Weight (kg)	Sales unit
K532	CONNECTOR CBS/CT 95 ZF A	Tinned brass	16-95	6-35	0.115	20
L232	CONNECTOR CBS/CT 95 ZF	Aluminium	16-95	2.5-35	0.117	20

SEE SHEET
INSTALLATION / LV insulated toolings